

A reliable partner for specimen preparation

Auto Slide Preparation System

AS-410M

Medical device manufacturing and sales notification number 26B2X10020201801  IVD



2020 Kyoto SME Technology Award Grand Prize Winner

HistoLab[®]

ESTABLISHED 1965

Optimizing & expediting

specimen preparation

Excellent specimen preparation, easy to achieve

The Auto Slide Preparation System AS-410M automatically sections paraffin-embedded sample blocks, a process that used to be performed only manually. This includes everything from sectioning to mounting the sections on slide glasses, subsequent stretching and drying. Moreover, the sections can be mounted on almost the same position on consecutive slides with a minimal unevenness in thickness. The System comes with an Automatic Blade Replacement Function as a standard feature to ensure safety during sectioning, and a mechanism that vacuums paraffin residue to simplify everyday maintenance. A wide range of options are available to customize the system specifications according to the scale and purpose of customers' needs. Optional features include a 96-Block Feeding Unit, 400-Slide Storage & Dry Unit, Sample Identification Function that prevents sample mix-ups, and a Blade Mark Check Function that prevents specimen quality decline due to blade scratches. The AS-410M can improve efficiency of specimen preparation and bring about significant operational changes, for example, through night-time operation.



Product Features:

1. Stable and accurate sectioning

This equipment prepares sectioned specimen with uniform thickness under a constant temperature and sectioning conditions.



Realization of constant quality sections
Comparison of the stained consecutive sections shows that sections are stained equally and the mounting positions are nearly uniform.

2. Designed to be safe

Automatic replacement of blades prevents injury.

3. Customizable specifications

A wide range of options are available to customize the specifications according to the scale and purpose of your facility.

4. Prevention of mix-ups

The System reads the barcode information on the cassette, which is then printed on the frosted end of the slides, preventing mix-ups of samples when sectioning.

Sectioning process: The embedded tissue blocks are automatically sectioned, mounted on a slide, stretched and dried.

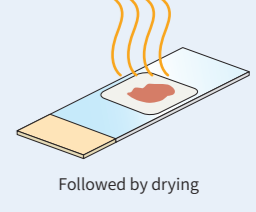
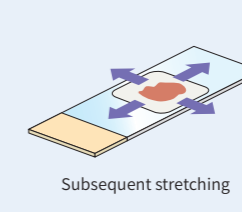
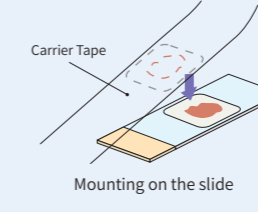
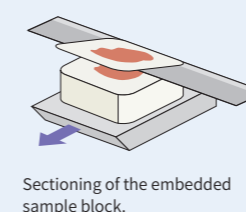

CUT

Accumulated trust in performance and quality

Great contribution to the efficiency of specimen preparation at medical institutions, pharmaceutical companies, CROs and public research institutes among others, around the world.

Automation improves labour shortages and workflows, and expedites diagnosis.

Standard functions

Automatic Blade Replacement Function

The microtome blades are automatically supplied from the dedicated replacement blade cassette, preventing injuries during replacements.

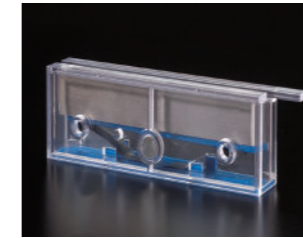

Dedicated Microtome Replacement Blades



Installation of the cassette

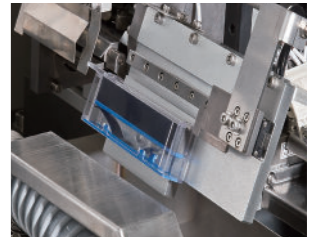

Installation completed

Automatic Orientation Function

After measuring the block surface angle and height, the tilt of the sample holder is automatically adjusted so that the block surface is parallel to the blade.

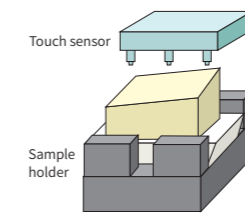

The block is placed under the touch sensor.

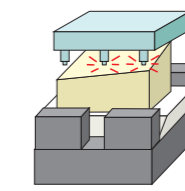

The touch sensor measures the surface angle and height.

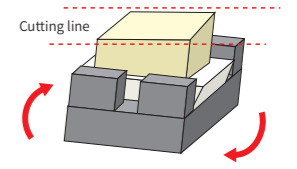

The sample holder component adjusts the tilt angle of the block and makes its surface parallel to the cutting line.

Automatic process using a carrier tape

The sections that have been cut, are attached on-the-fly to the tape and are automatically transferred to the slide glass.

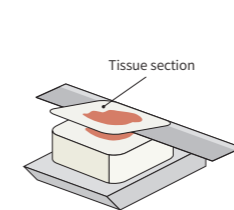

A tissue section of the specified thickness is made using a sectioning blade. At the same time, the tissue section is attached on-the-fly to the carrier tape.

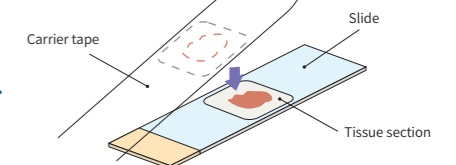
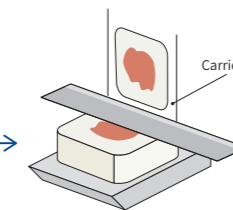

The section attached to the carrier tape is mounted on the slide glass.

Temperature Control Function (internal and stretching board)

The temperature inside the system is controlled using a cooler, in order to keep the sectioning environment constant. In addition, the temperature for stretching and drying can be adjusted to ensure optimum results.



Thermoregulator (stretching unit)

Thermoregulator (drying unit)

Interval Cut Function

Serial sectioning by intervals can be performed by setting the number of layers and the interval (thickness) in between while keeping the same depth of intervals.

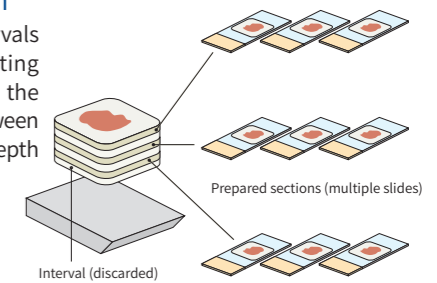

Interval (discarded)

Prepared sections (multiple slides)

Sectioning Pressure Monitoring Function

The pressure on the block during sectioning is monitored and if the blade cuts in too deep, the operation is stopped to prevent damage to the sample. Thanks to a unique algorithm, it is also possible to change the sectioning conditions according to the pressure.

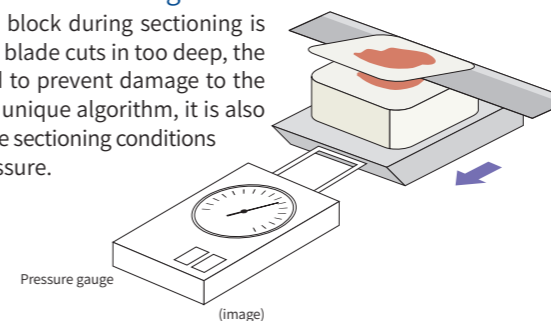

Pressure gauge

(image)

Paraffin Waste Suction Function

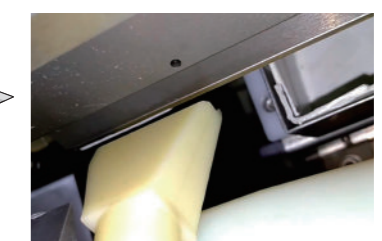

Paraffin residue generated during sectioning is suctioned and collected to reduce the daily cleaning load.

Paraffin waste suctioner



VIEW

Responding to your needs through technical skills and experience.

Achieving fine quality specimen and uniform positioning.
Improving workflow in your laboratory by automating this process.

Optional functions

Sample Identification Function (BR)

The barcode information printed on the cassette is read and printed on the slide glass to prevent sample mix-ups.

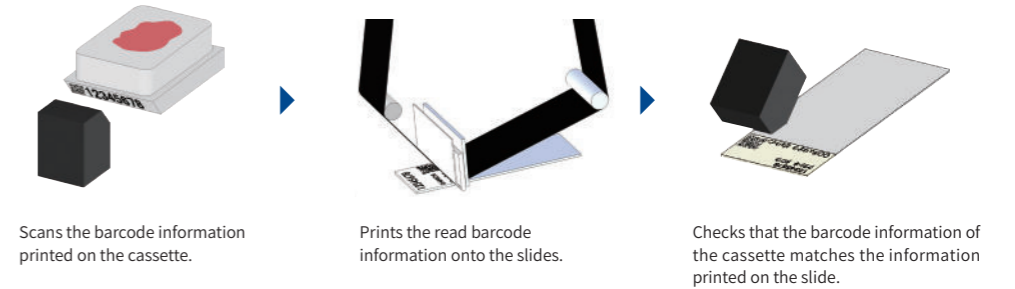

Dual Mounting Function (TM)

Up to two sections from the same block can be attached on a slide.

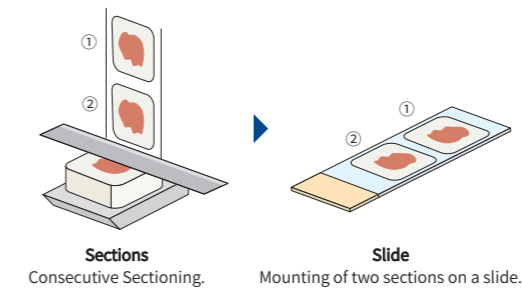

External PC connection (LK-400)

The System is connected to the facility through a computer that can prompt the start of operation according to the specified sectioning parameters after receiving the barcode information printed on the sample block cassettes. It can also print the information necessary for the specimen.



Blade Mark Check Function (DB)

The section mounted on the slide is photographed, and if a blade scratch is detected, the position of the blade is changed or it is replaced so that the same doesn't occur for the rest of the sectioning.

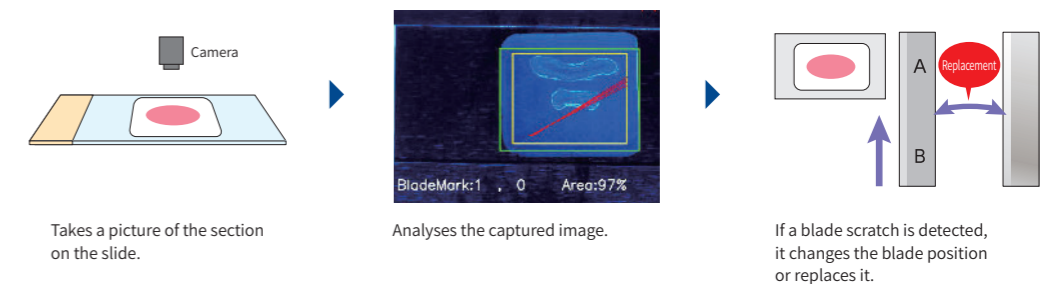

Surface Temperature Detection Function (BT)

The block surface temperature is measured and the sectioning starts only when this is below a certain level, improving the quality of the sections.

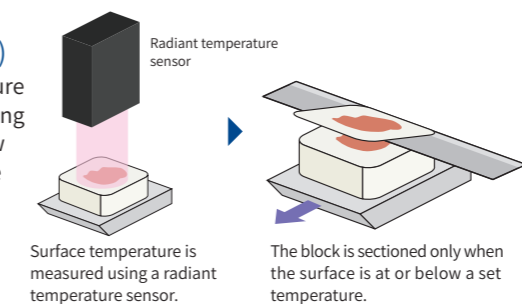

Email Notification Function (RM)

The System sends email notifications about the operation status and the occurrence of errors to the user's terminal.

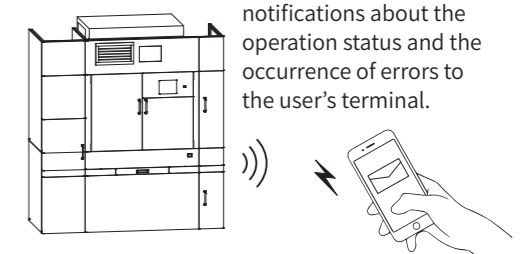

Auto-Trimming Function (FS)

The sample block is photographed before and after trimming using our unique optical technology. The two images are then compared to determine the trimming condition.

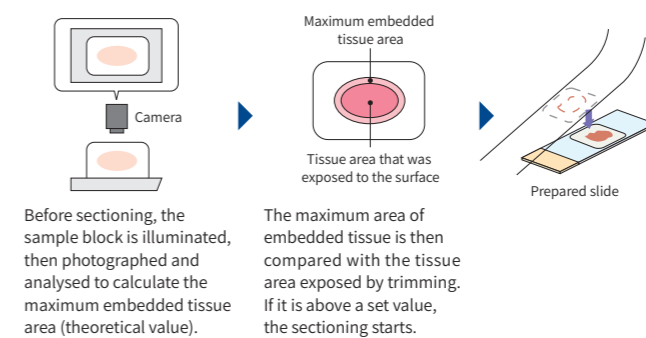

400-Slide Feeding Unit (SS)

It is possible to install up to 4 Slide Glass Cassettes that can store 100 slides each. Different types of slides can be set in each cassette.



*This function may not be available for samples whose contours are difficult to detect due to colour tone.



USE

Specifications can be selected to meet your needs.

The System can be customized according to the number of blocks to be processed. By installing only the necessary functions, wasteful costs are reduced.

Available Expansion Units

Combinations of 24 or 96 block feeding units and 100 or 400 slide storage/drying units are available.

System 1

■ Dimensions (W×D×H in mm)
1,280×700×1,980
(Excluding protrusions)

■ Weight
Approx. 800kg

Installation space

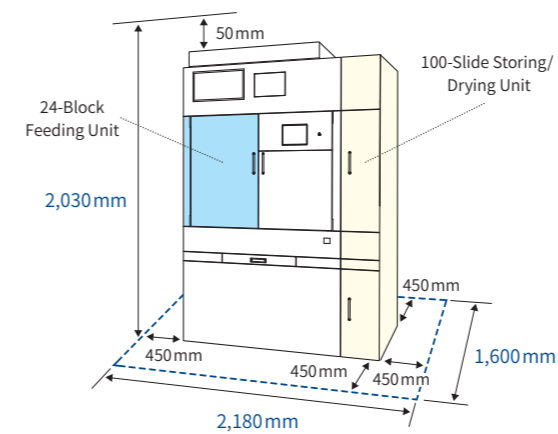

System 2

■ Dimensions (W×D×H in mm)
1,550×700×1,980
(Excluding protrusions)

■ Weight
Approx. 900kg

Installation space

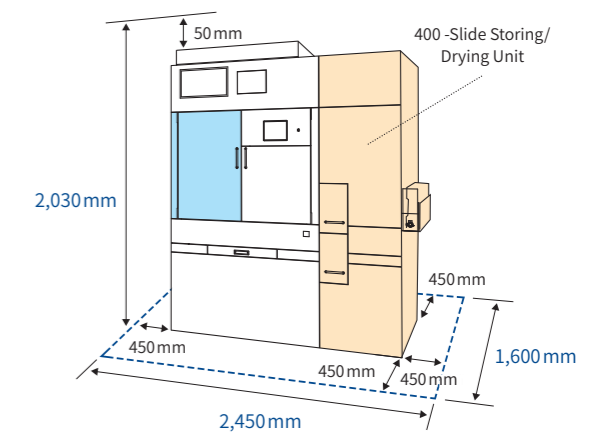

System 3

■ Dimensions (W×D×H in mm)
1,680×700×1,980
(Excluding protrusions)

■ Weight
Approx. 950kg

Installation space

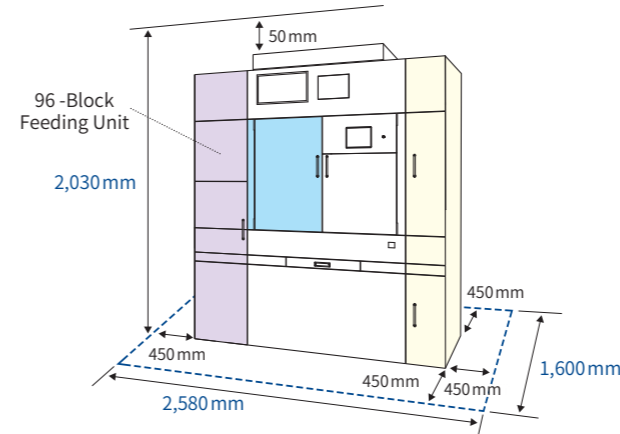

System 4

■ Dimensions (W×D×H in mm)
1,950×700×1,980
(Excluding protrusions)

■ Weight
Approx. 1,050kg

Installation space

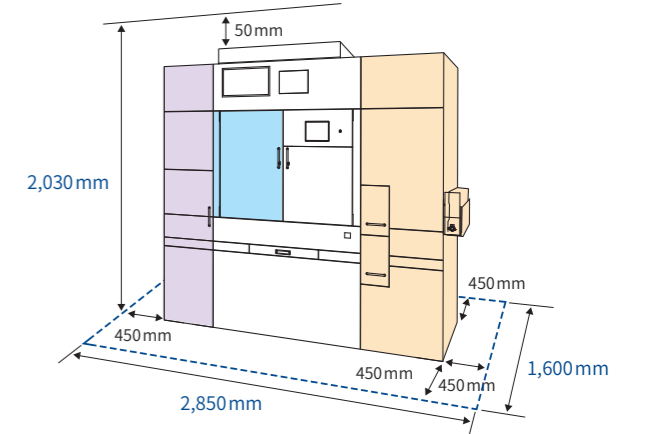

96-Block Feeding Unit

400-Slide Dry Chamber Unit

Combinations of Block Feeding Units and Dry Chamber Units

	24-block	96-block
100-slide storage capacity	System 1	System 3
400-slide storage capacity	System 2	System 4

Consumables



Product name	Carrier Tape (plastic film)
Model	CT-10R
Quantity	300 m-roll × 10 pcs.
The section is attached to the carrier tape and transferred to be mounted on a slide glass.	



Product name	Dedicated Microtome Replacement Blades (Feather)
Model	F-50
Quantity	50 blades × 5 boxes
The blade cassette is fixed on the Automatic Blade Change Unit with a magnet. The automatic replacement of the blades prevents injuries during operation.	



Product name	Thermal Ink Ribbon
Model	SR-4
Quantity	4 pcs.
A set of ink ribbons and cores for the printer mounted on the Sample Identification Function (BR).	



Product name	Filter
Model	A-50728
Quantity	10 sheets
The paraffin residue suctioned by the Paraffin Waste Suction Function is collected by the filter installed in this mechanism.	



Product name	Prefilter
Model	A-50463
Quantity	1 pc.
Container for the above filters that collect the paraffin residue suctioned during the sectioning process.	



Product name	Slide Tray
Model	SG-10
Quantity	5 trays × 10 pcs.
20 pcs. for the 100-Slide Drying Unit (standard specification) 80 pcs. for the optional 400-Slide Drying Unit	

Accessories



Product name	Sample Tray
Model	ST-24
Quantity	1 pc.
1 tray for the 24-Block Feeding Unit (standard specification) 4 trays for the optional 96-Block Feeding Unit	



Product name	Slide Glass Cassette
Model	SGC-100
Quantity	1 pc.
1 pc. for the 100-Slide Drying Unit (standard specification) 4 pcs. for the optional 400-Slide Drying Unit	



Product name	Slide Glass Collection Box
Model	SGB-100
Quantity	1 pc.
1 pc. for the 100-Slide Drying Unit (standard specification) 4 pcs. for the optional 400-Slide Drying Unit	



Product name	Humidifying Water Tank
Model	KT
Quantity	1 pc.
A tank for the humidification during sectioning.	



Product name	Waste Water Tank
Model	HT
Quantity	1 pc.
A tank for drainage from the cooler.	



Product name	Compressor Oil (JUN-AIR)
Model	SJ-27
Quantity	1 bottle
Oil for the compressor required to supply compressed air to a part of the drive unit of the device.	

*Maintenance contracts are also available. Please contact us for details.
*AS-410M is a product developed and manufactured by Dainippon Seiki Co., Ltd. under a license agreement with Shibaura Machine Co., Ltd. and Kanagawa Academy of Science and Technology (KAST).

AS-410M Specifications

Block* ¹ setting capacity	24 blocks (standard), 96 blocks (option)
Slide* ² setting capacity	100 slides (standard), 400 slides (option)
Slide storage capacity	100 slides (standard), 400 slides (option)
Compatible slide size	76 x 26 x 1 (mm). Some types of coating on the glass surface cannot be used.
Settable range of section thickness	3-10 μm
Compatible block size	From 24 x 24 x 5 (mm) to 37 x 24 x 14 (mm) * ³ * ⁴ It can be sectioned until it remains up to about 3 mm in height.
Compatible block cassette size	40 x 28 x 6 (mm), 40 x 28 x 12 (mm) Not compatible with larger block cassettes.
Processing time	About 2.5 minutes per block* ⁵ (when making two sections from an already trimmed block)
Operating and setting interface	Touch panel
Ambient temperature	10 to 28 °C
Ambient humidity	30 to 70% RH (Non-Condensing)
Power source	AC 100/110/120/220/230/240 V 50/60Hz Single-phase 1.5KVA x 3 systems
Compressor (air pressure)	0.7 MPa (100 psi)
Noise level	63 dB

*¹ Use paraffin with a melting point of 56 to 62°C. *² When using adhesive microscope slides, choose hydrophilic glasses. *³ If you wish to use sample sizes not listed here, please contact us. *⁴ Depending on the surface angle of the blocks, the processing may not be successful, even if their dimensions are within the acceptable range. *⁵ Varies depending on section parameters.

Options

Model	Product name	Details
BS-96	96-Block Feeding Unit	24 Sample Trays × 4 pcs.
SS	400-Slide Feeding Unit	100 Slide Glass Cassette × 4 pcs.
DU-400	400-Slide Dry Chamber	100 Slide Glass Collection Box × 4 pcs.
FS	Auto-Trimming Unit	CCD camera, lighting for photographing and computer for analysing* ¹ , PC desk* ²
BR	Sample Identification Unit	Barcode reader, printing function
BT	Surface Temperature Detection Function	Radiant temperature sensor
DB	Blade Mark Check Unit	CCD camera, lighting for photographing and computer for analysing* ¹ , PC desk* ²
TM	Dual Mounting Unit	Dedicated dripping water unit for mounting
LK-400	External PC Connection Expansion package	LK-400 software and dedicated computer Handy barcode reader, PC desk* ²
RM	E-mail Notification Function	Communication terminal

*¹ When both the auto-trimming and the blade mark check functions are installed, only one computer will be provided.
*² Only one set of PC desk is included.

Products and specifications are subject to change without notice to account for improvements.

Distributor

**Biomedical Division
Dainippon Seiki Co., Ltd.**

Tanatsugu 8 Kotari, Nagaokakyo, Kyoto Prefecture, Japan
TEL +81-75-951-8801 FAX +81-75-952-8778
www.dnseiki.co.jp/en/



Histolab Products AB

Södra Långebergsgatan 36
436 32 Askim, Sverige

Phone: +46 (0)31-709 30 30

Mail: mail@histolab.se

www.dnseiki.co.jp/en/

www.histolab.se